



## Fingerarm System – Assembling & Mounting

Example: Triple Level

### TOOLS REQUIRED



- 1 Dig the hole and mount your posts in position required for your signage.

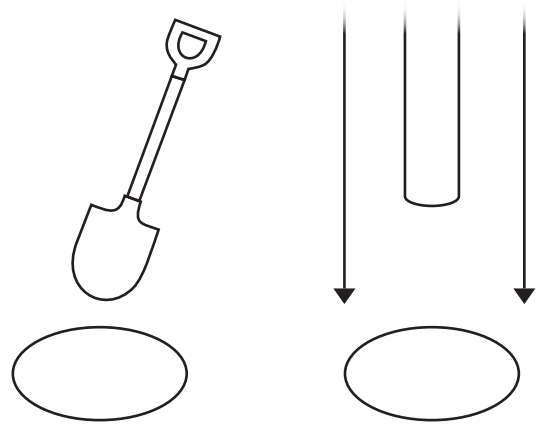

- 2 Slide the 1st Finger arm onto the post leaving enough space for the other two finger arms and a finial if you need to. Point the finger arm in the direction you require it and then tighten the grub screw to lock into place.

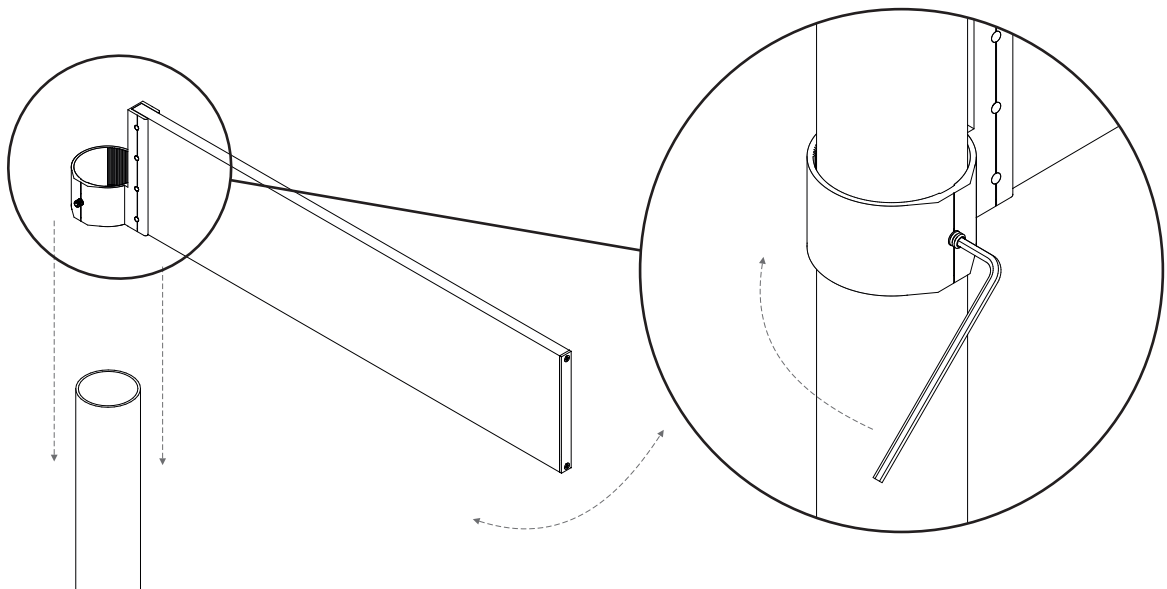

# Tripoint

3

Slot the 2nd Finger arm (Centre Bracket) on top of the bottom finger arm and position as required, then tighten the grub screw to lock the finger arm into place.

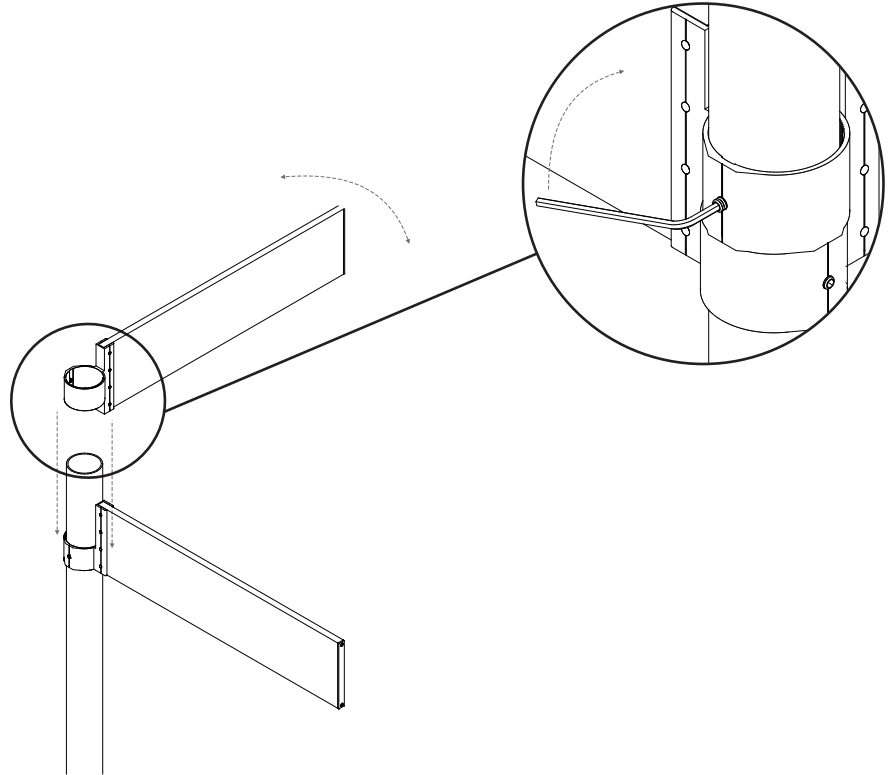

4

Slide the 3rd Finger arm onto the top of the 2nd finger arm bracket and position in place. Tighten the grub on the bracket to lock into position.

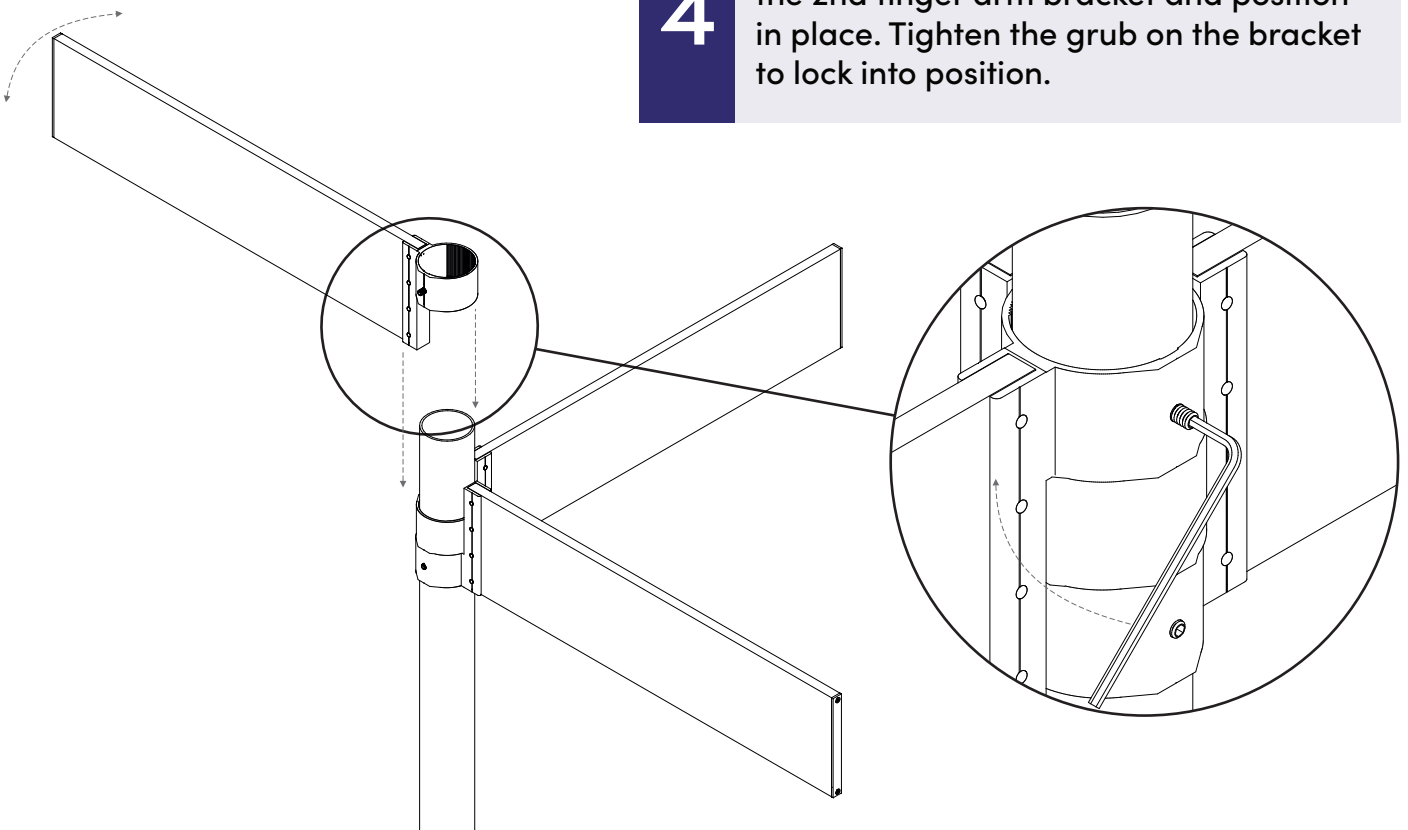



5

If you are fitting a finial place it on top of the post and tighten into place using the grub screw (Post Caps are also available).

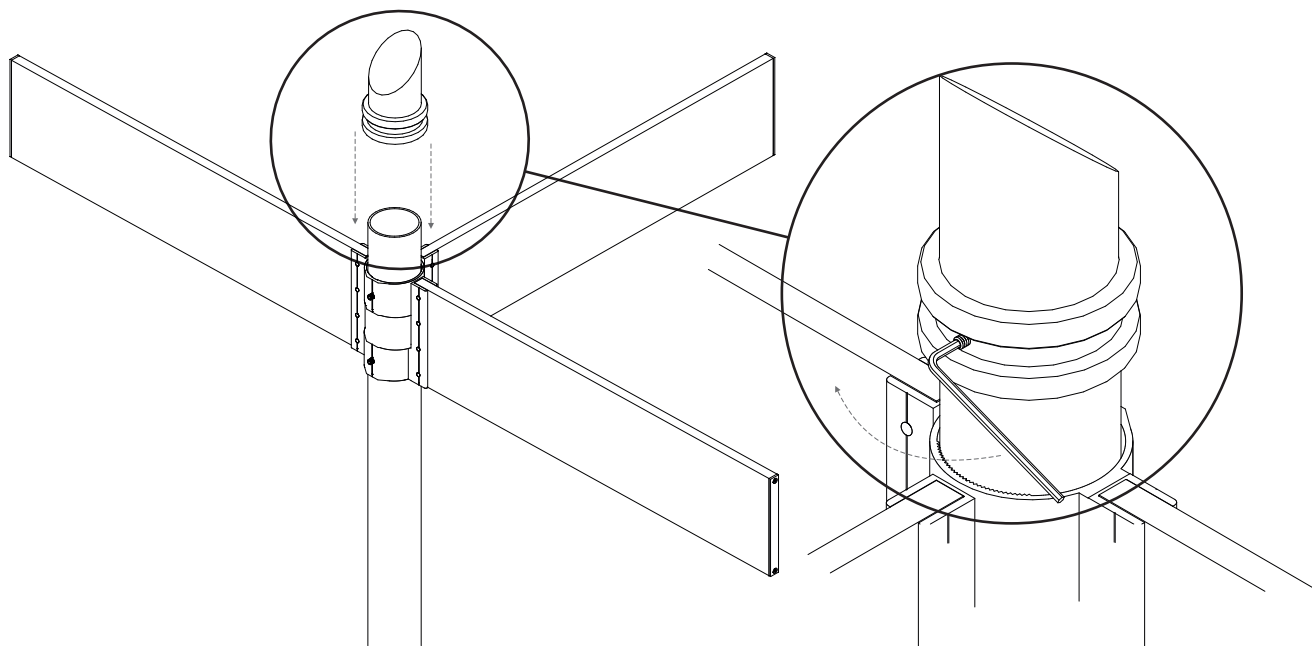

6

Your OCTApoint Finger arm system is now fitted.

